

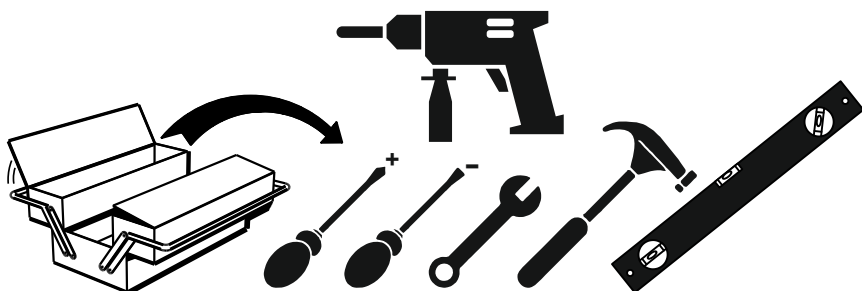

MULTIMO

1113 STUDIO 5

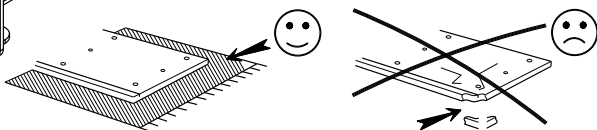
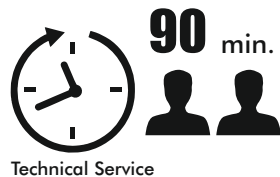
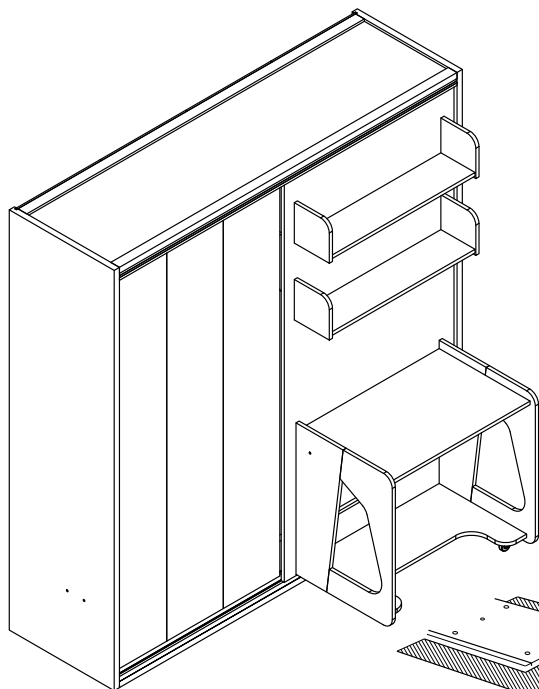

VIDEO

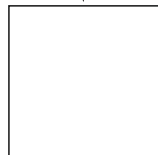









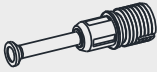



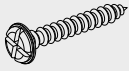
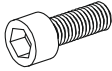
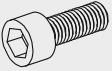
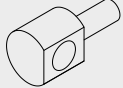
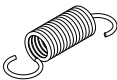
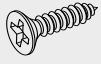
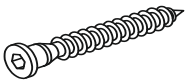
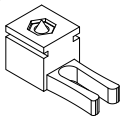
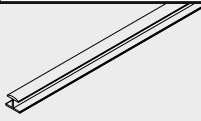
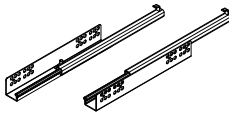

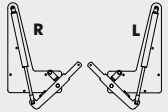

link

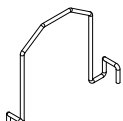
Assembly Instructions

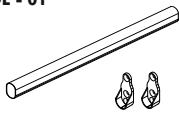
Track Title	(inch)				(mm)			
	Piece	Thickness	Length	Width	Piece	Thick	Height	Most
A (R-L)	2	1,18	81,89	23,62	2	30	2080	600
B	1	0,71	75,98	23,62	1	18	1930	600
C	1	0,71	75,98	22,83	1	18	1930	580
D	1	0,71	79,53	19,29	1	18	2020	490
E	1	0,71	37,64	18,50	1	18	956	470
F	1	0,71	37,64	18,50	1	18	956	470
G	1	0,71	37,64	18,50	1	18	956	470
H	1	0,71	37,64	7,87	1	18	956	200
I	2	0,71	7,87	18,31	2	18	200	465
K	2	1,18	13,78	18,50	2	30	350	470
L	2	0,71	37,64	5,12	2	18	956	130
M	1	0,71	9,84	4,92	1	18	250	125
N	1	0,71	31,50	20,47	1	18	800	520
O	1	0,71	31,50	13,78	1	18	800	350
P	1	0,71	31,50	5,91	1	18	800	150
R	1	0,71	31,50	19,69	1	18	800	500
S (R-L)	2	0,71	29,53	10,59	2	18	750	269
T (R-L)	2	0,71	29,53	14,76	2	18	750	375
U	2	0,71	32,28	7,68	2	18	820	195
Y (R-L)	4	0,71	7,87	7,87	4	18	200	200
Z	2	6,10	35,04	16,54	2	155	890	420
Q	1	0,71	77,87	38,19	1	18	1978	970
W	1	0,71	77,87	38,19	1	18	1978	970
X / X-1	4	0,31	81,06	19,13	4	8	2059	486

Accessories List

<p>MNX 02</p>  <p>54 / piece</p>	<p>MNG - 01</p>  <p>54 / piece</p>	<p>KVL 01</p>  <p>84 / piece</p>	<p>TAP - 01</p>  <p>54 / piece</p>
<p>AVT - 01</p>  <p>10 / piece</p>	<p>VD - 02 (3,5x25) mm</p>  <p>42 / piece</p>	<p>IM - 02 (6x20) mm</p>  <p>2 / piece</p>	<p>IM - 01 (6x30) mm</p>  <p>2 / piece</p>
<p>OT 01</p>  <p>4 / piece</p>	<p>YY 01</p>  <p>2 / piece</p>	<p>VD - 03 (3,5x18) mm</p>  <p>4 / piece</p>	<p>VDA - 01 (6,5x50) mm</p>  <p>6 / piece</p>
<p>STP - 01</p>  <p>4 / piece</p>	<p>H 01</p>  <p>3 / piece</p>	<p>RYP - 02</p>  <p>2 / piece</p>	<p>ER - 01</p>  <p>8 / piece</p>
<p>MKZ - 01D</p>  <p>1 / piece 450N</p>	<p>CTYSB - 01 (6x10) mm</p>  <p>8 / piece</p>	<p>TKR - 01</p>  <p>4 / piece</p>	<p>TAP - 02</p>  <p>20 / piece</p>
<p>TTC 01</p>  <p>3 / piece</p>	<p>SKT - 01</p>  <p>2 / piece</p>	<p>BOL - 01</p>  <p>1 / piece</p>	
<p>ADP - 02</p>  <p>1 / piece</p>	<p>PORT - 01</p>  <p>1 / piece</p>	<p>LED - 02</p>  <p>1 / piece</p>	

R

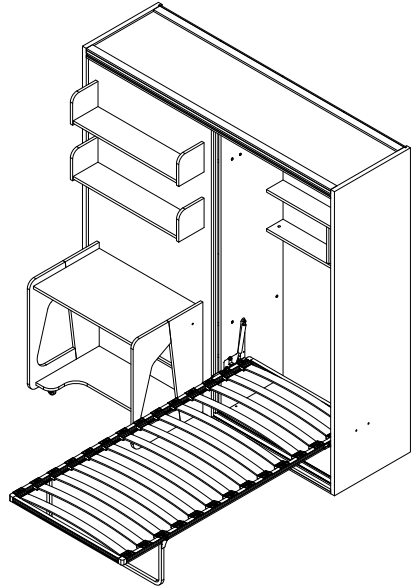
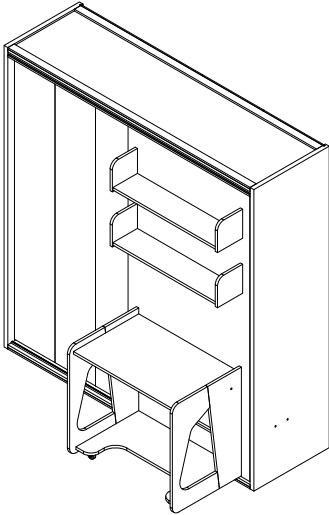

L

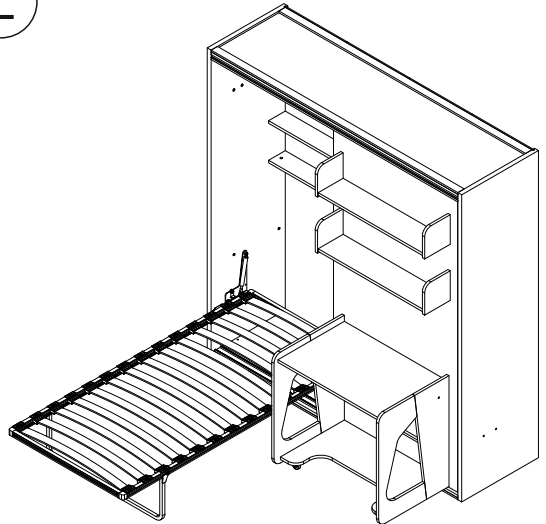
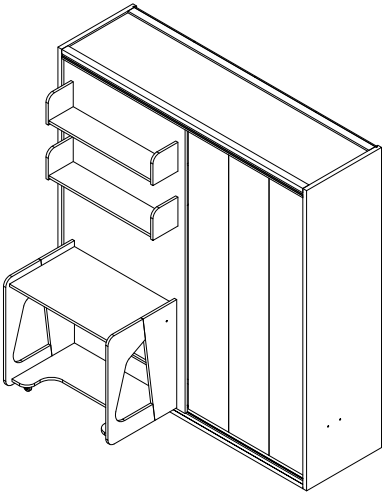

(R)

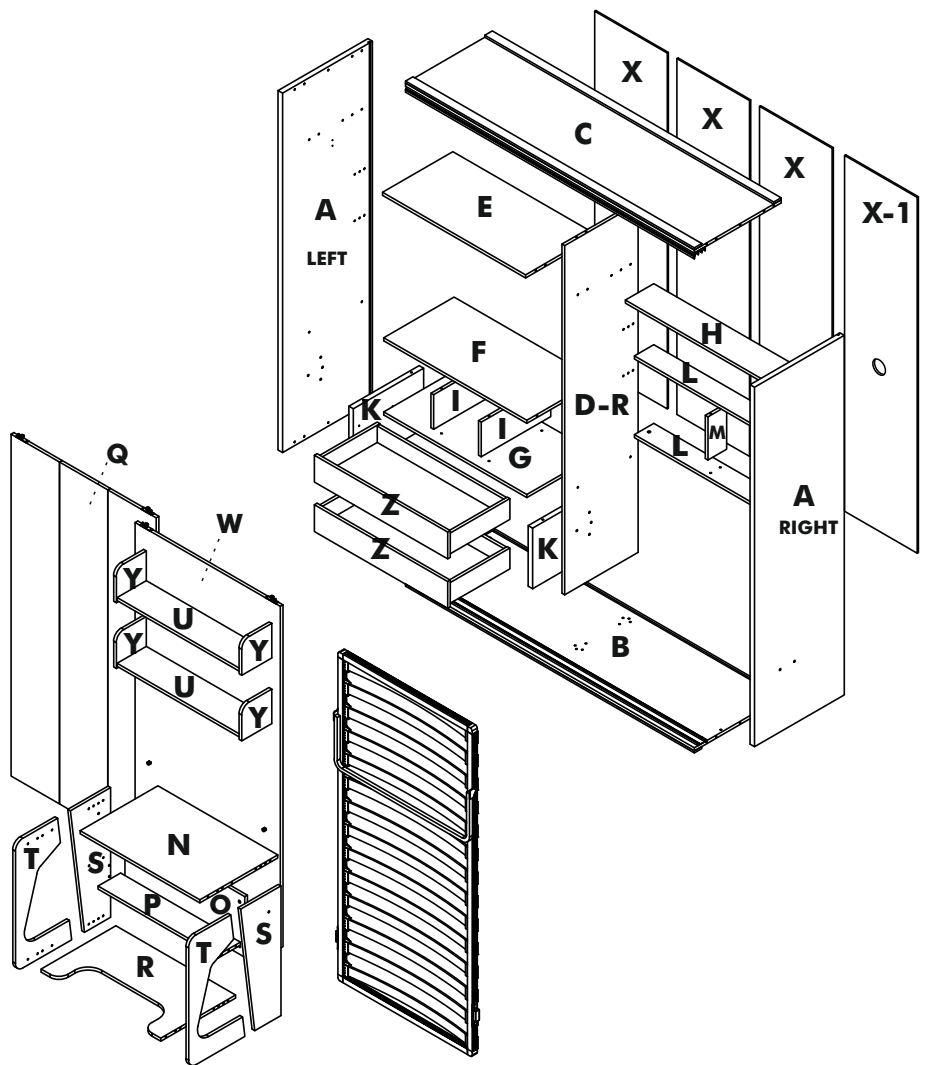

STEP 1

**PS; IN ORDER TO TIGHTEN MNX-02, THE RAIL MUST BE REMOVED FIRST.
RAIL WILL BE ASSEMBLED BACK , AFTER MNX-02 TIGHTENING COMPLETED (STEP 14).**

**NOT; MNX-02 SIKABİLMEK İÇİN ÖNCE RAY SÖKÜLÜR.
MNX-02 SIKIMI BİTİMİ İLE (STEP 14) RAY GERİ MONTE EDİLİR.**



MNX - 02

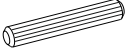

KVL 01

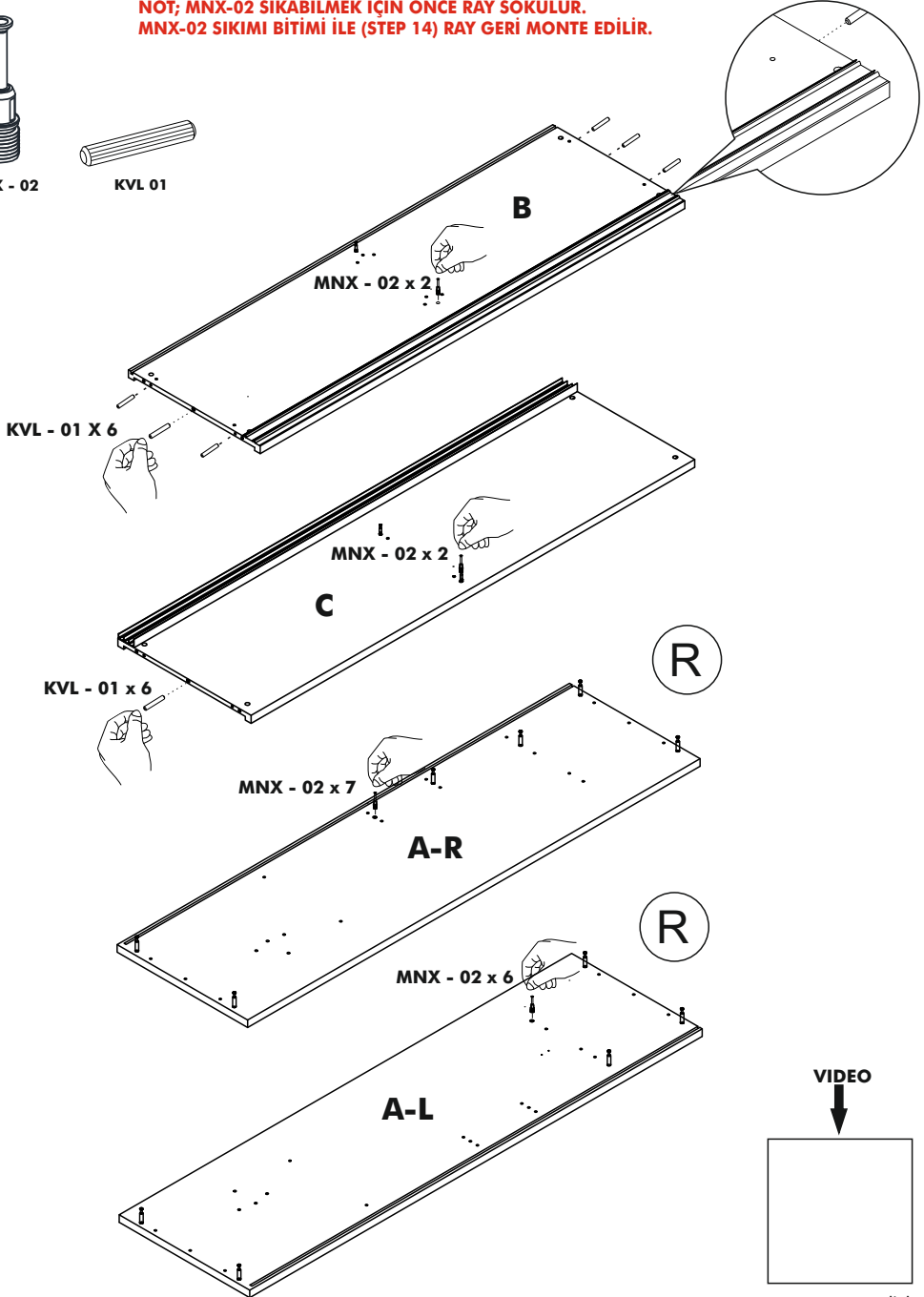

STEP 2

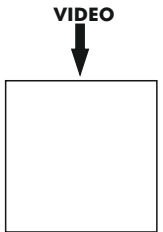
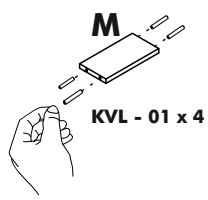
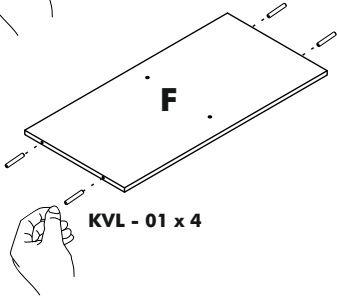
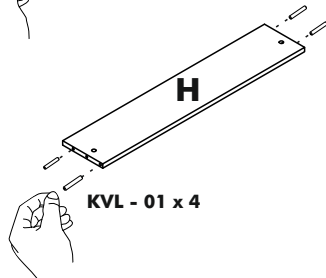
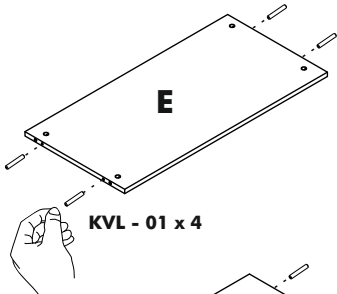
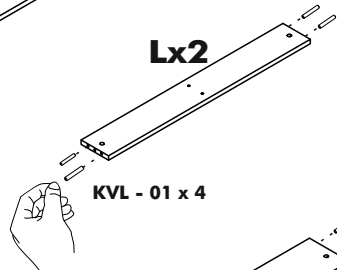
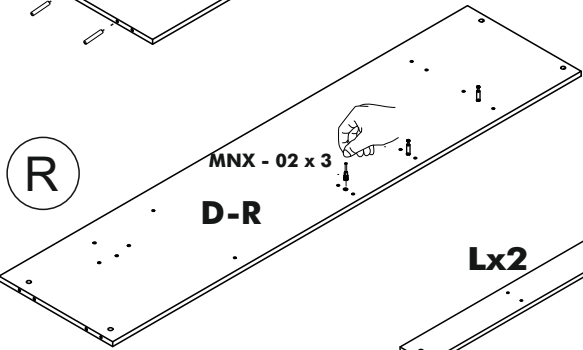
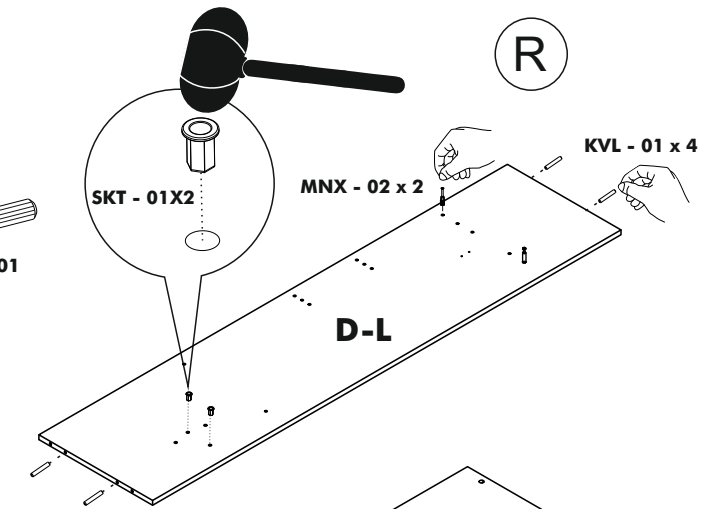
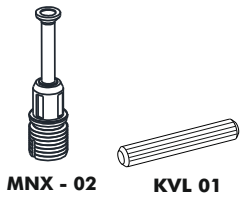

STEP 3

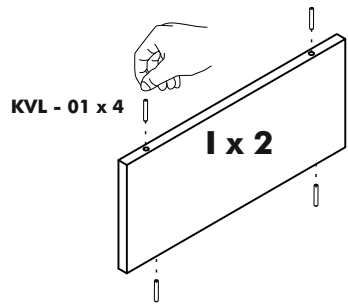
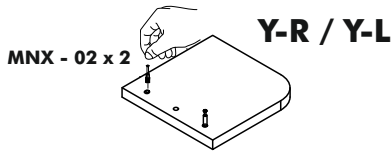
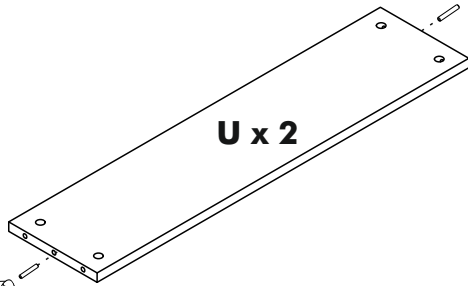
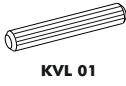

STEP 4

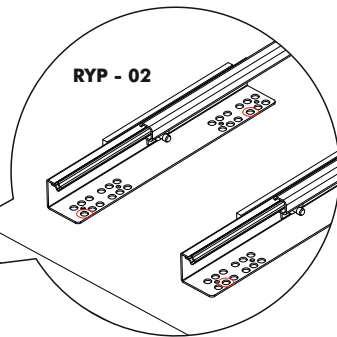
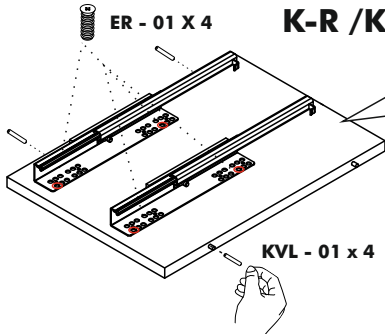
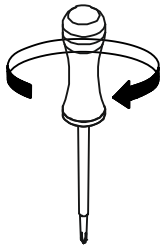

VIDEO
↓

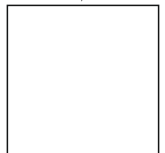

link

STEP 5

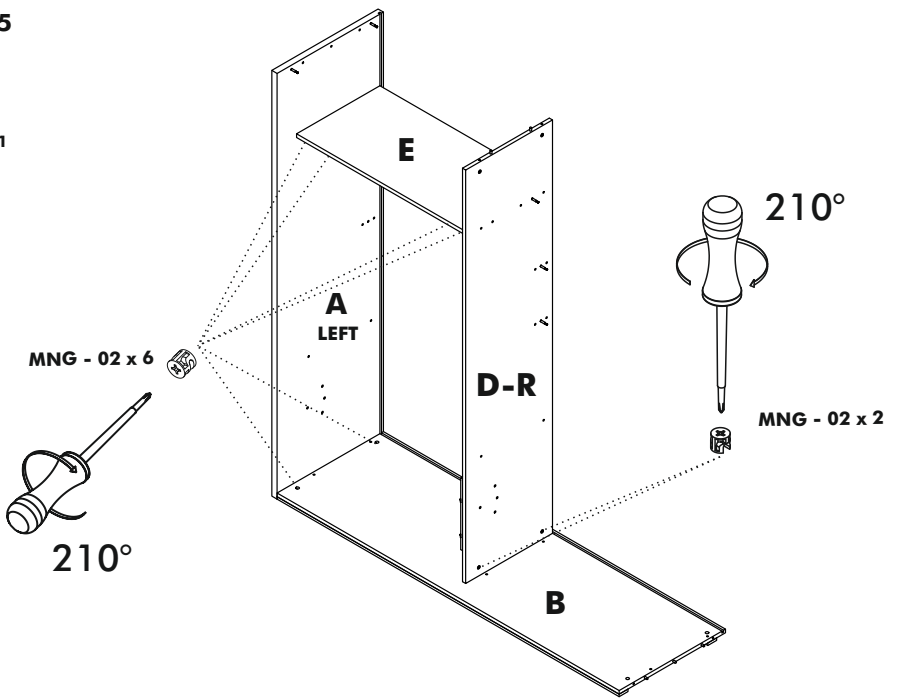

STEP 6

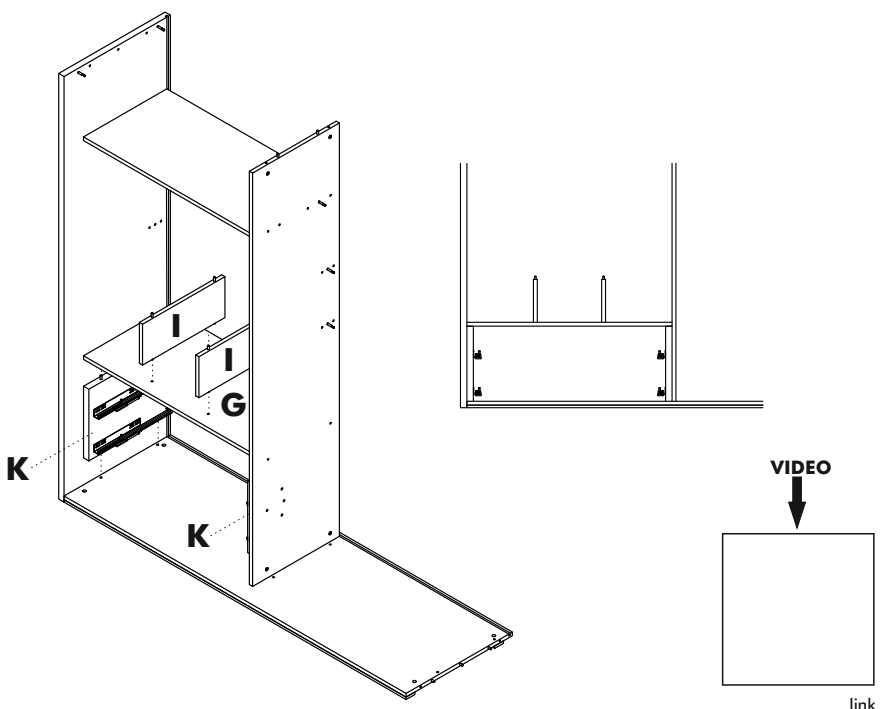

STEP 7

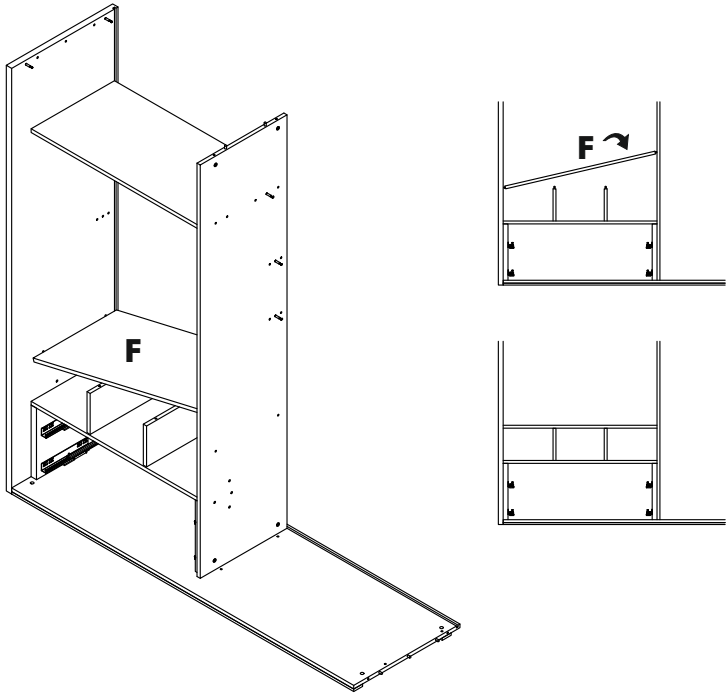

STEP 8



MNG - 01

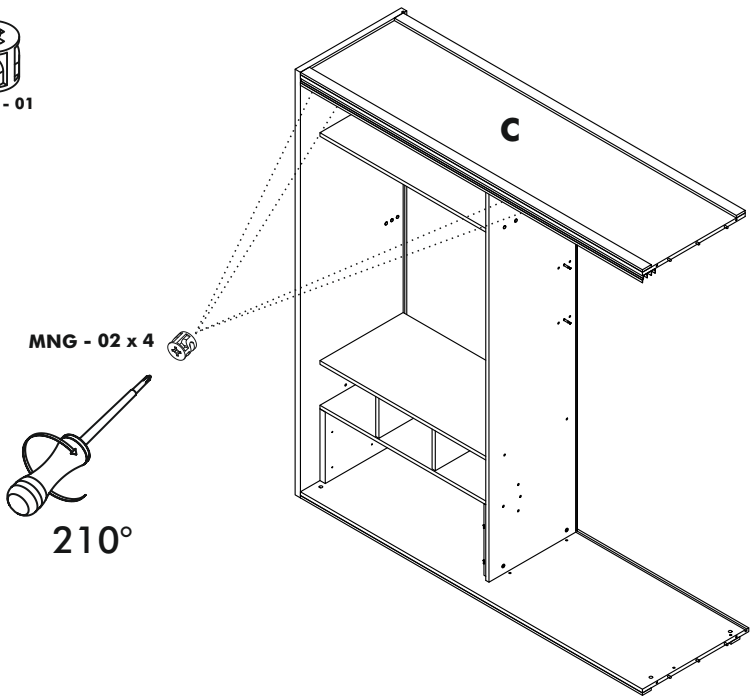

VIDEO

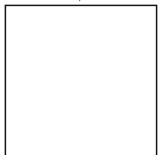

link

STEP 9

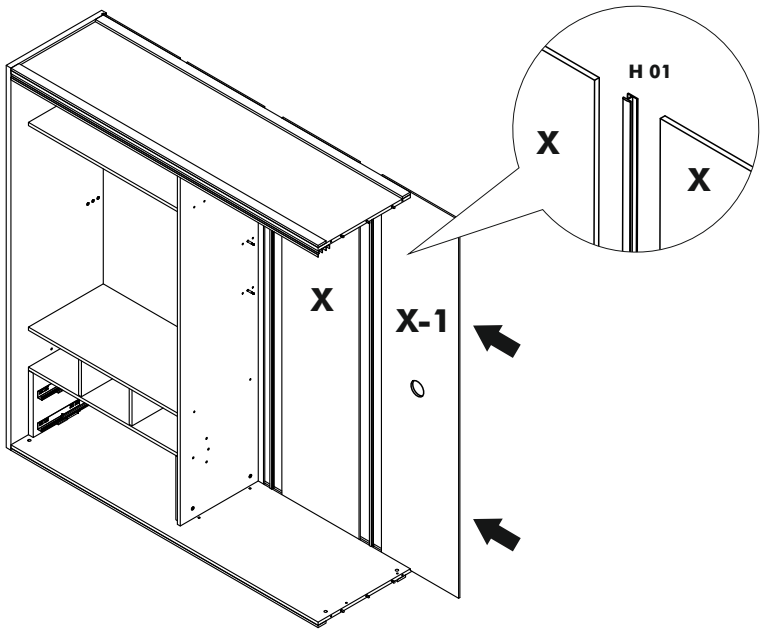

STEP 10

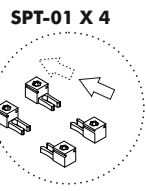
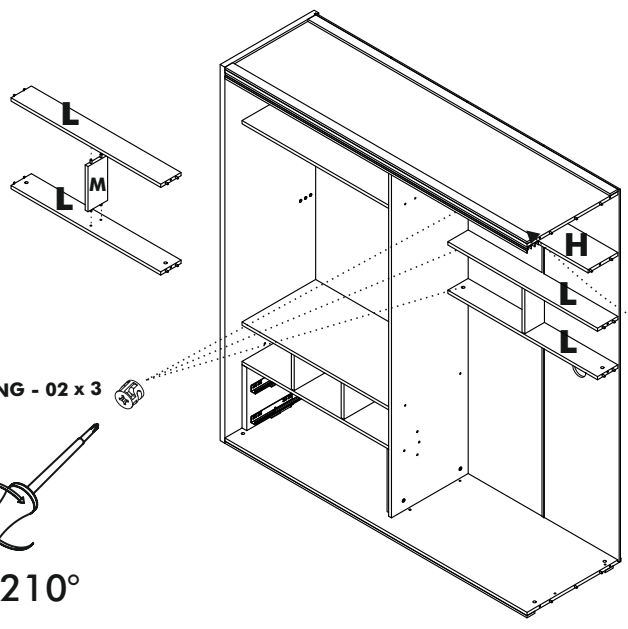

VIDEO
↓

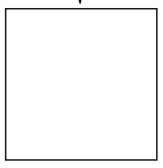

link

STEP 11



MNG - 01

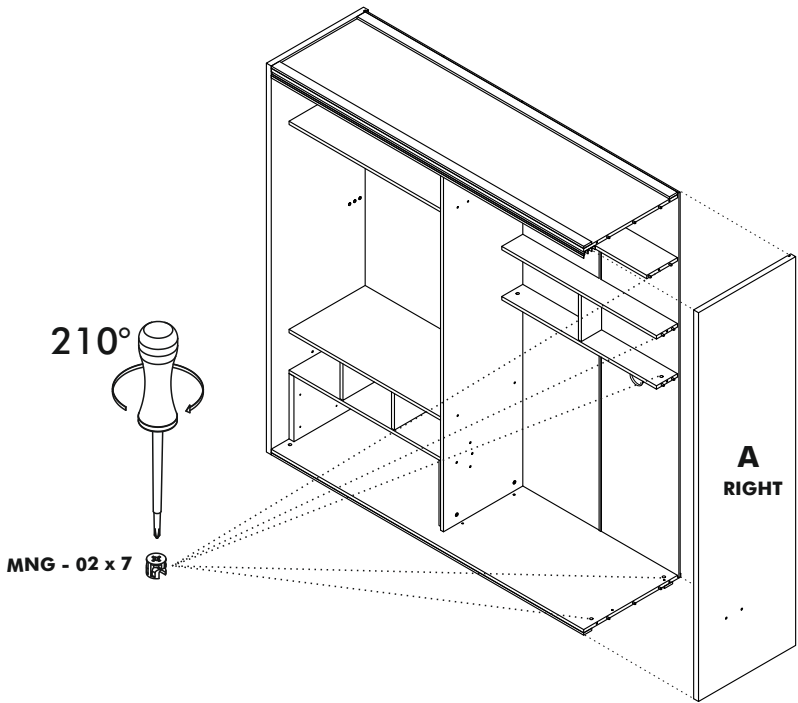

STEP 12

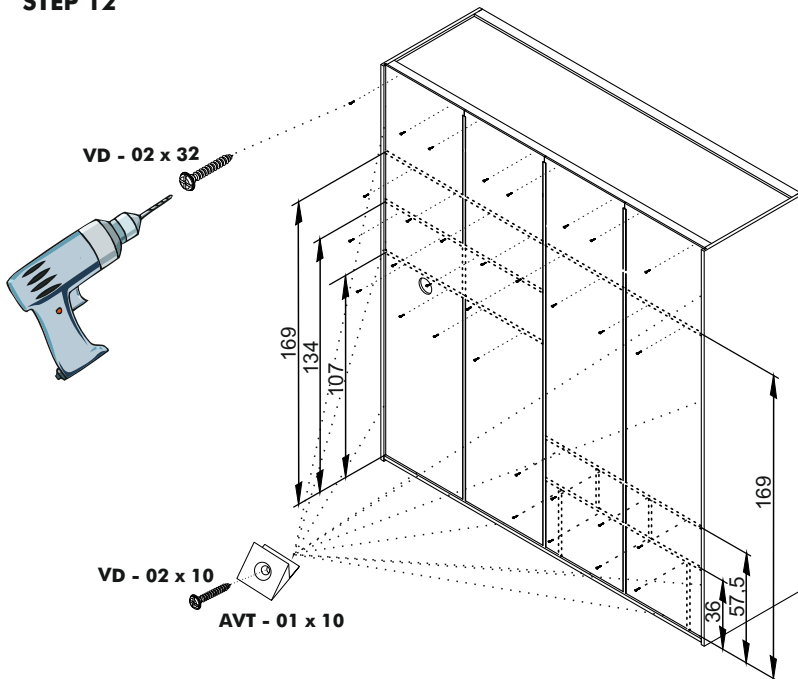

VIDEO

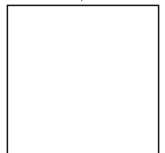

link

STEP 13

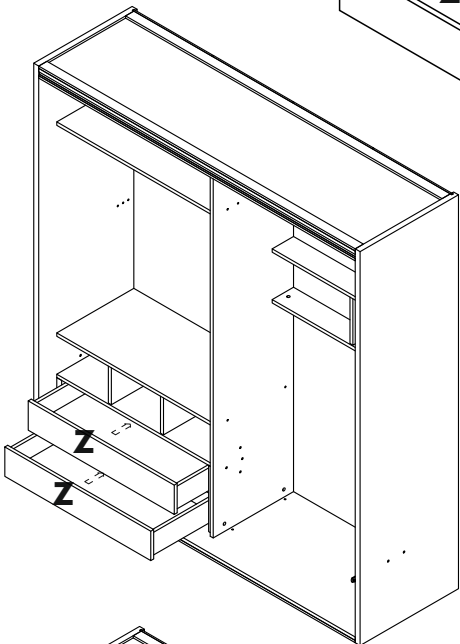
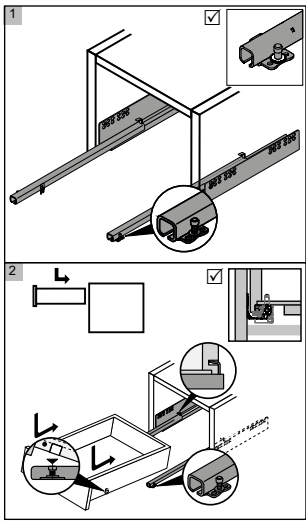
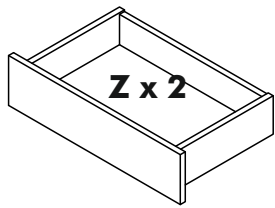

STEP 14

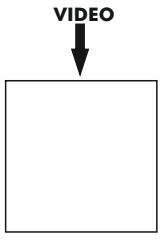
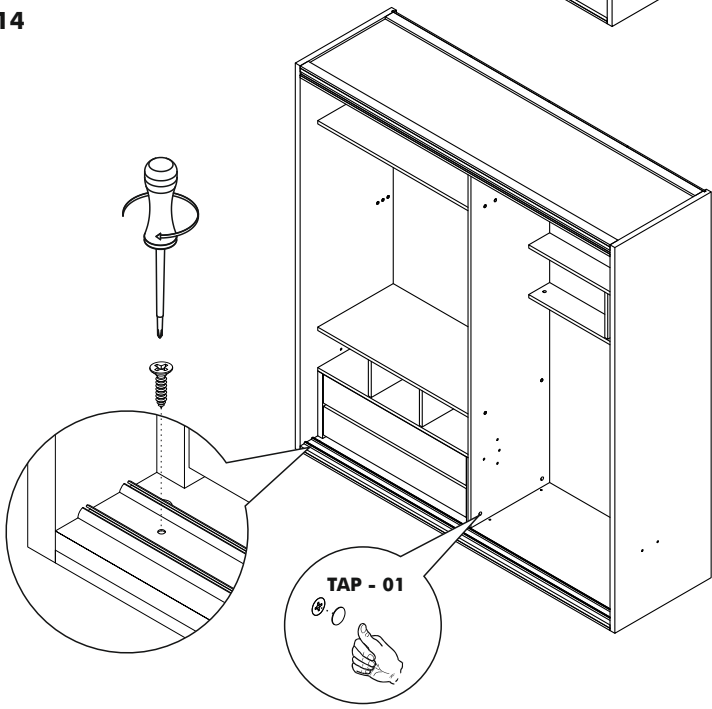

STEP 15

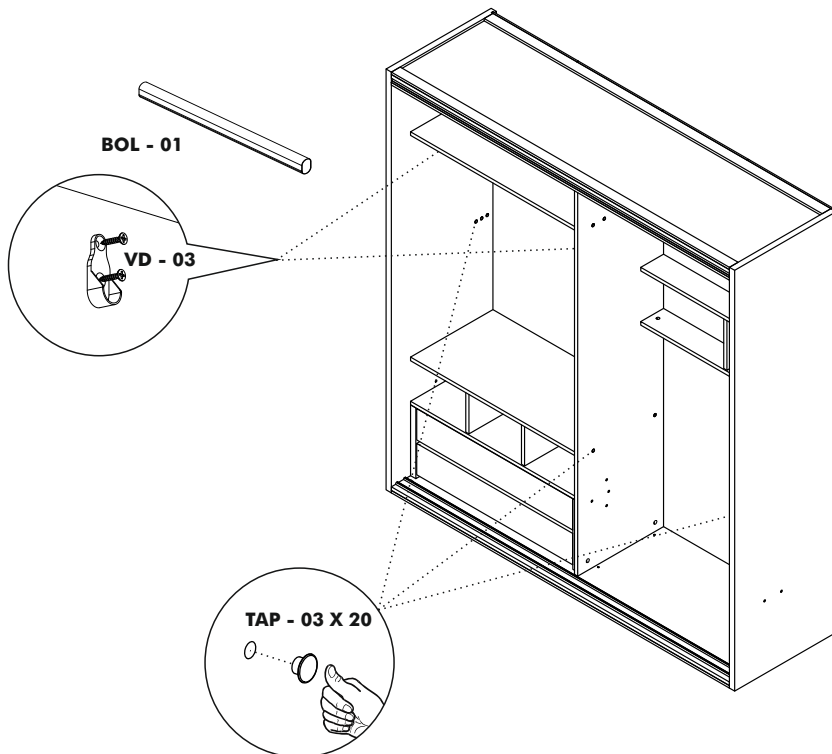
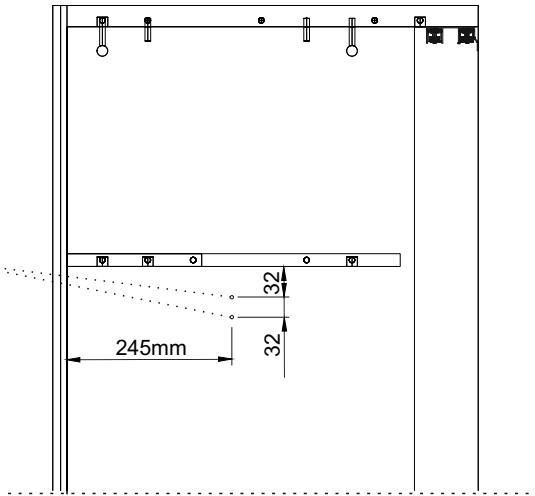

VIDEO

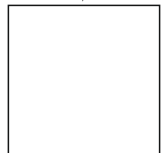

link

STEP 16

**Remove the screw
Vidayı çıkarın**



**CAUTION
DO NOT UNLOCK
BEFORE INSTALL**

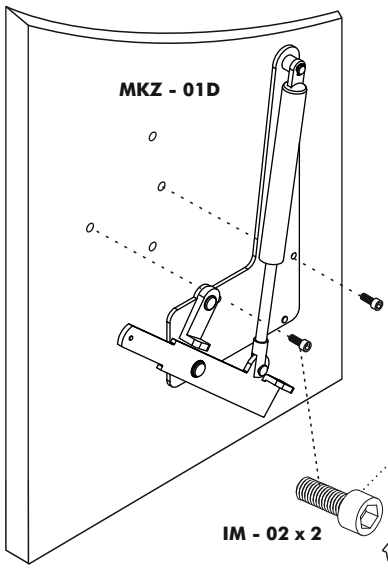
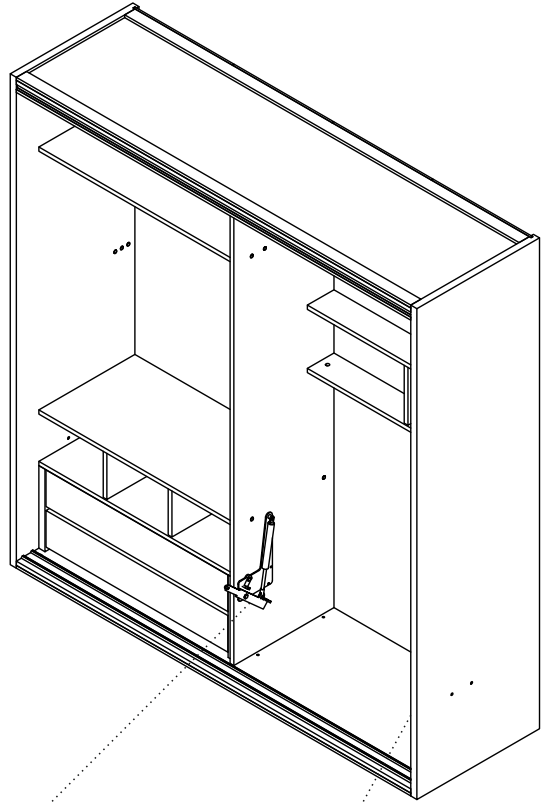

MKZ - 01D

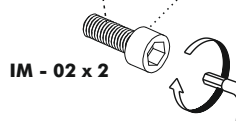

IM - 02 x 2



AL - 02

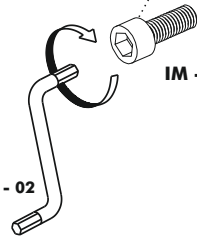

IM - 01 x 2

VIDEO

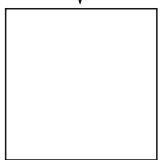

link

STEP 17

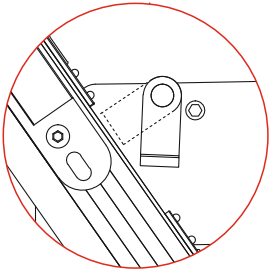
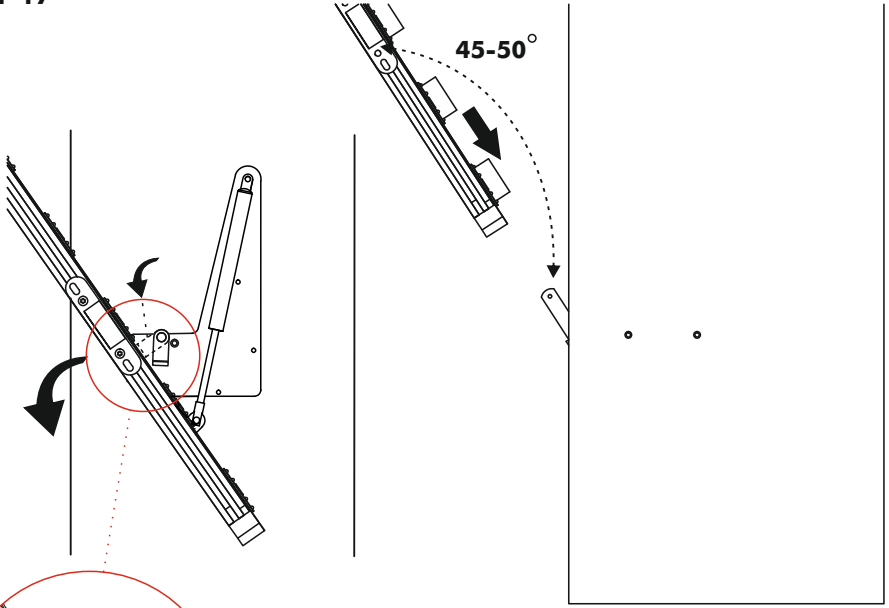

**LET THE STOPPER LOCK MOVE DOWN !!!
KAPAK KAPATILMADAN KİLİDİ İNDİRİN !!!**

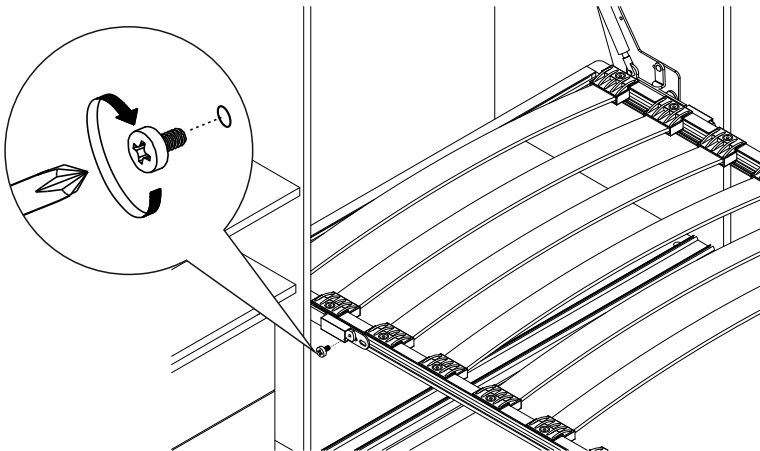

VIDEO

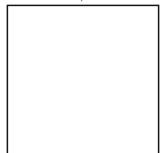

link

STEP 18

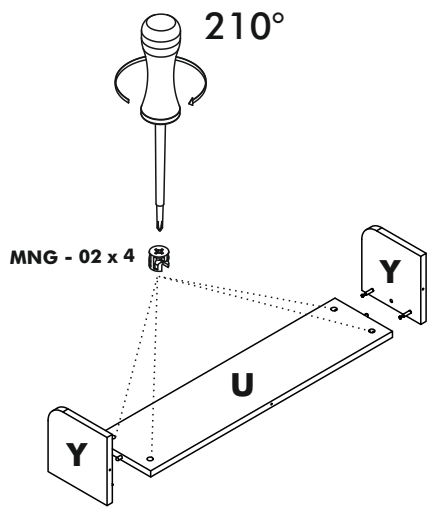

STEP 19

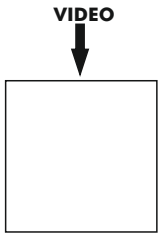
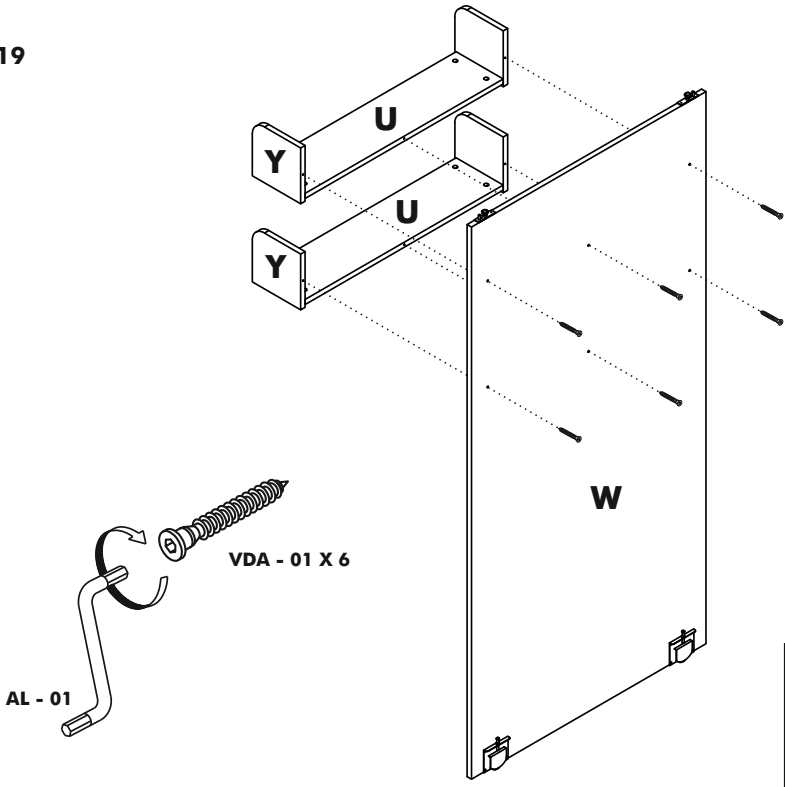

STEP 20

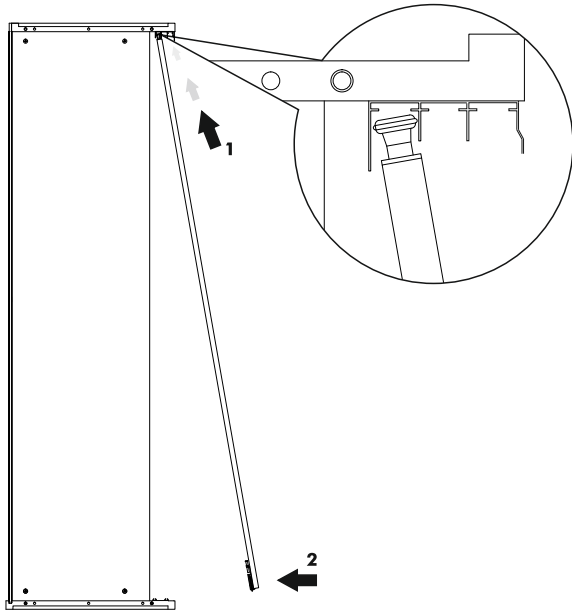

STEP 21

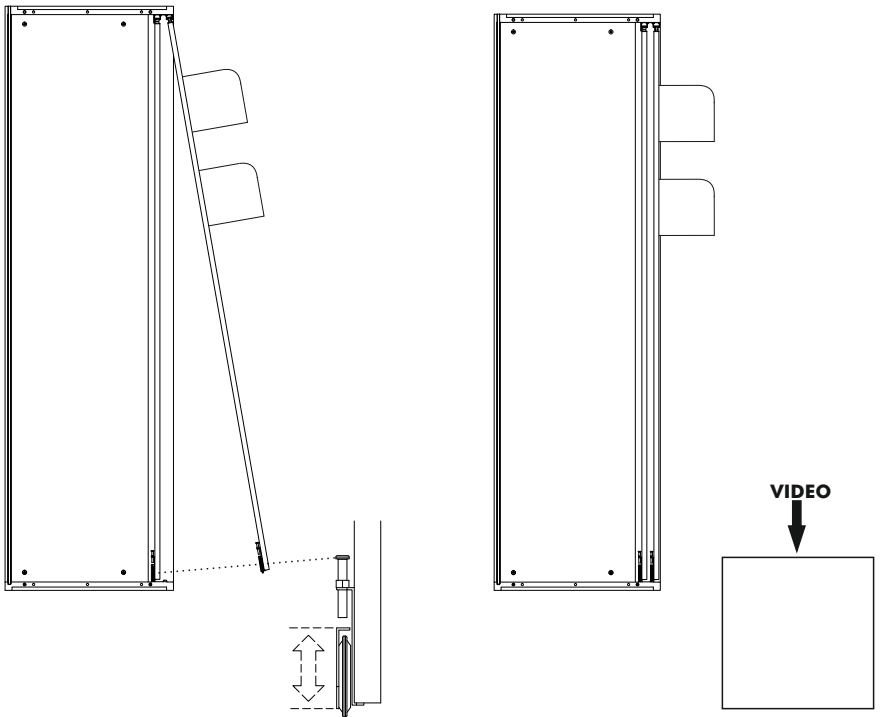

STEP 22

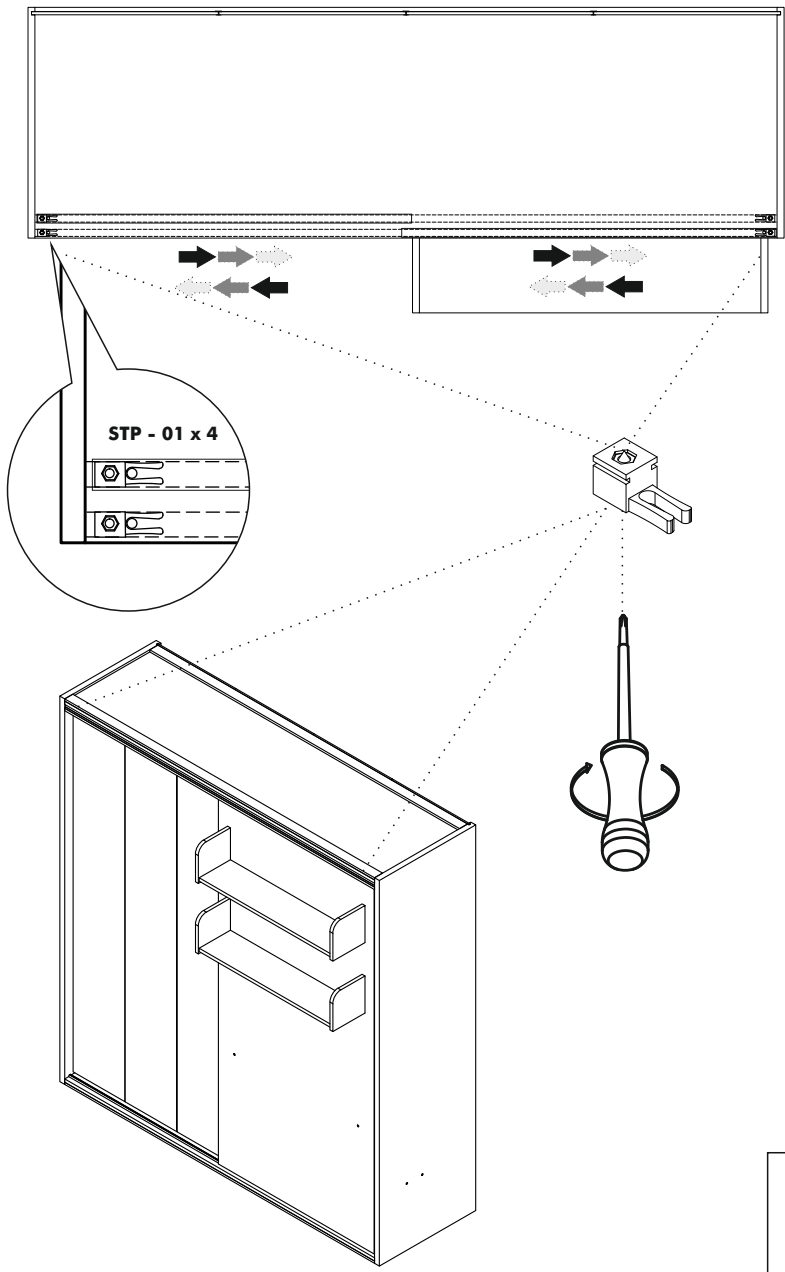

VIDEO

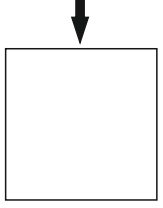

link

STEP 23



MNX - 02

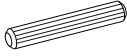

KVL 01

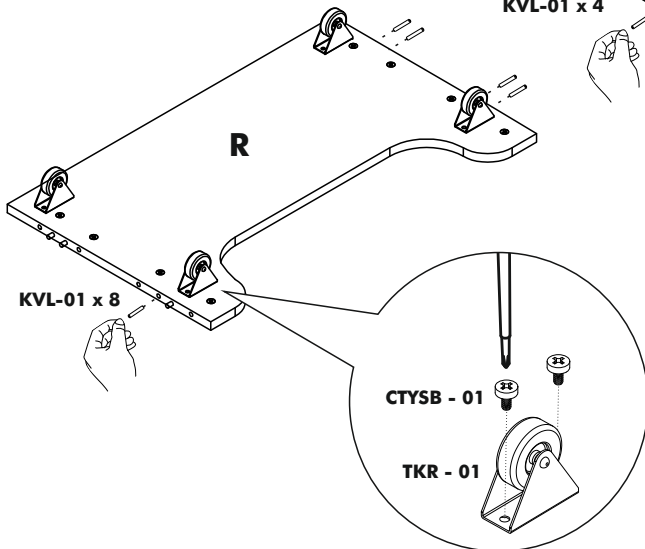
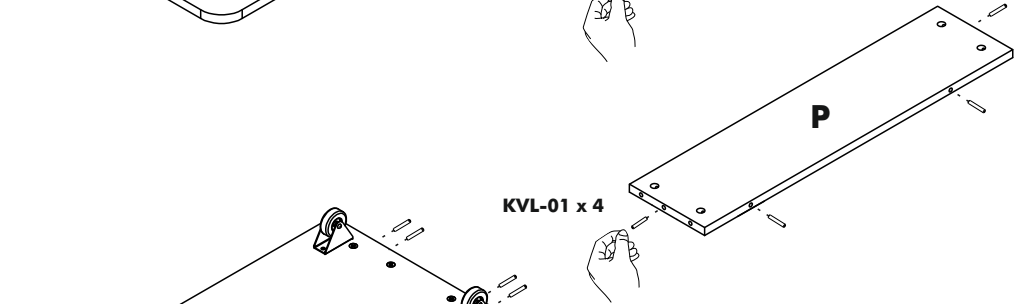
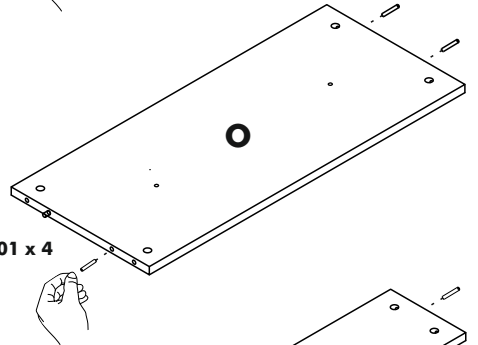
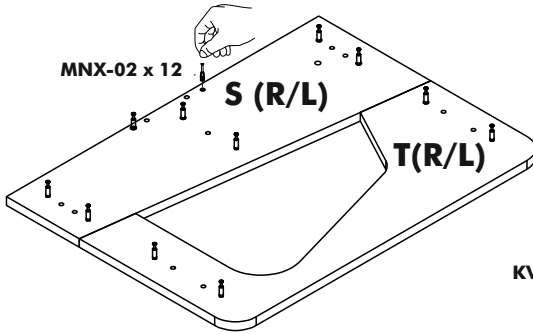
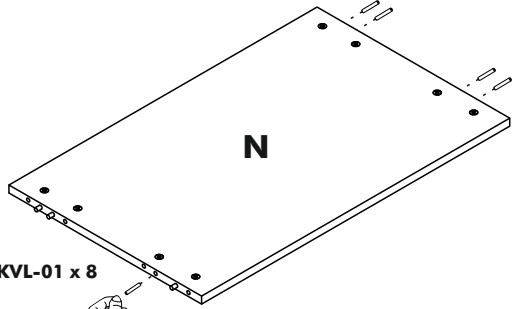

VIDEO

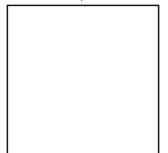

link

STEP 24

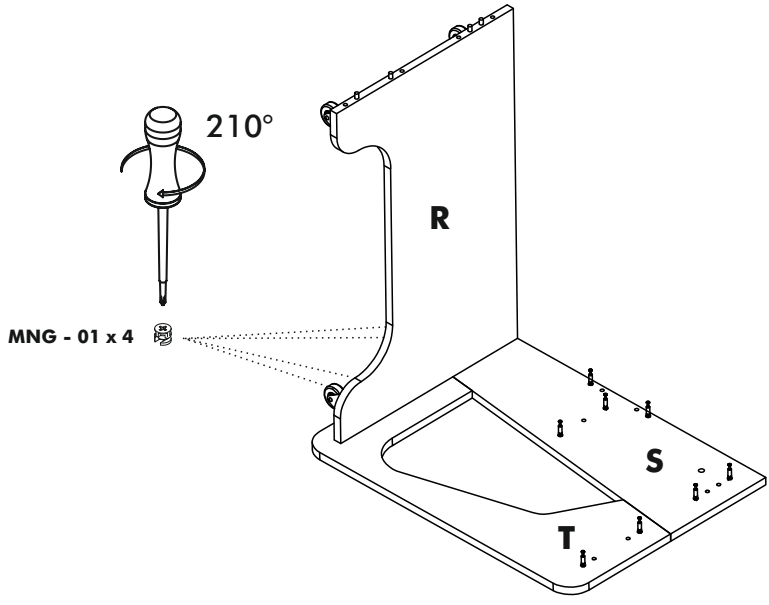

STEP 25

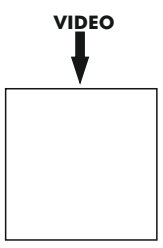
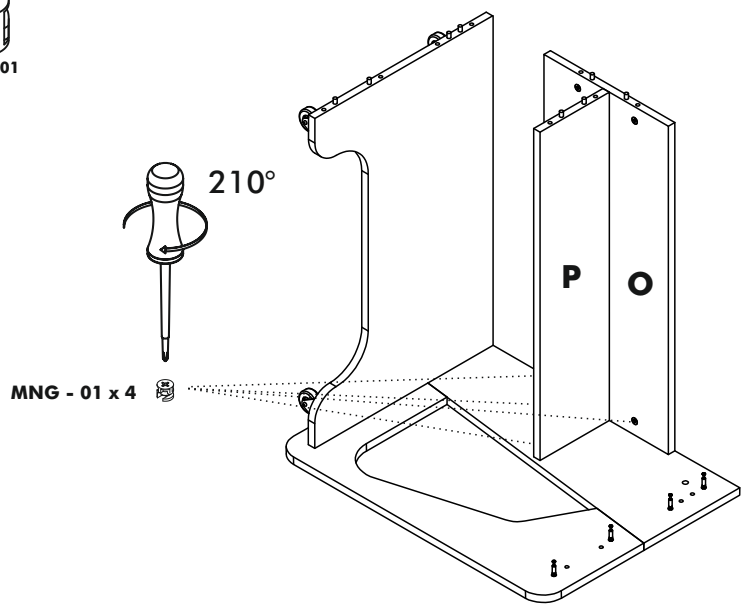

STEP 26

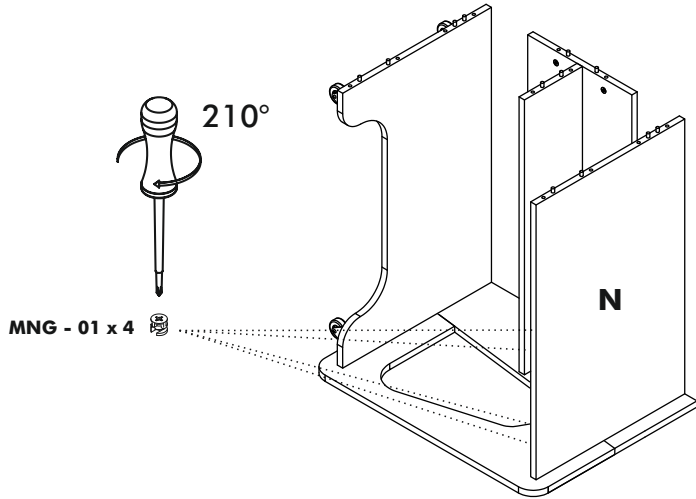

STEP 27

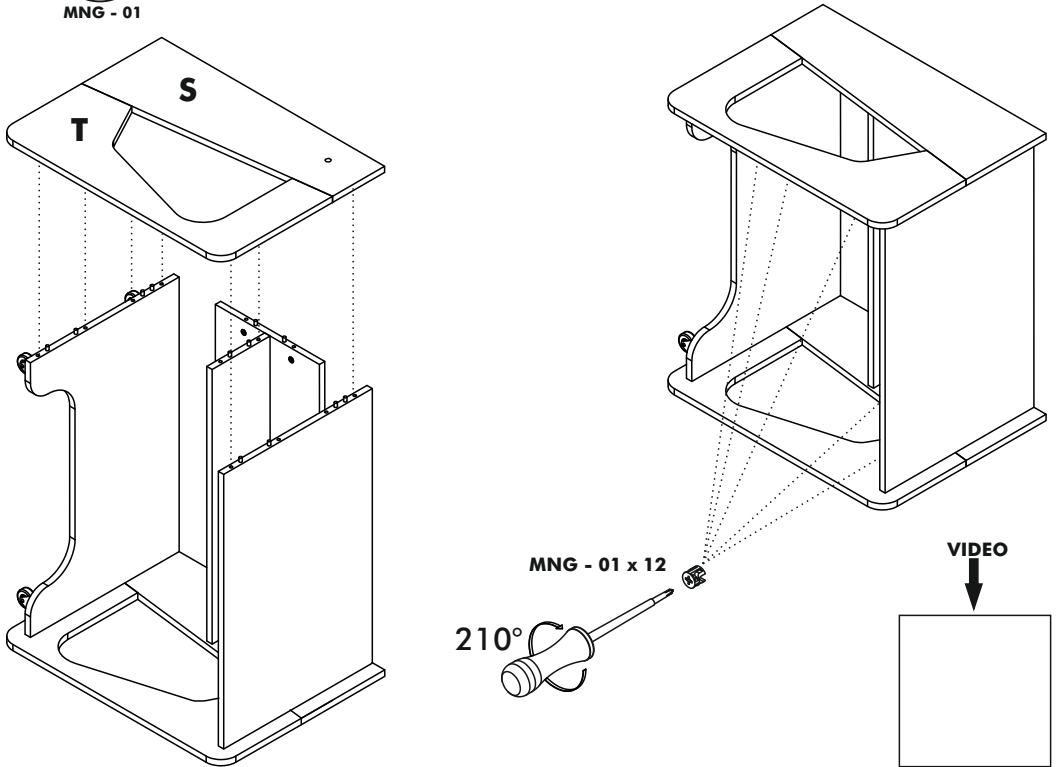

STEP 28

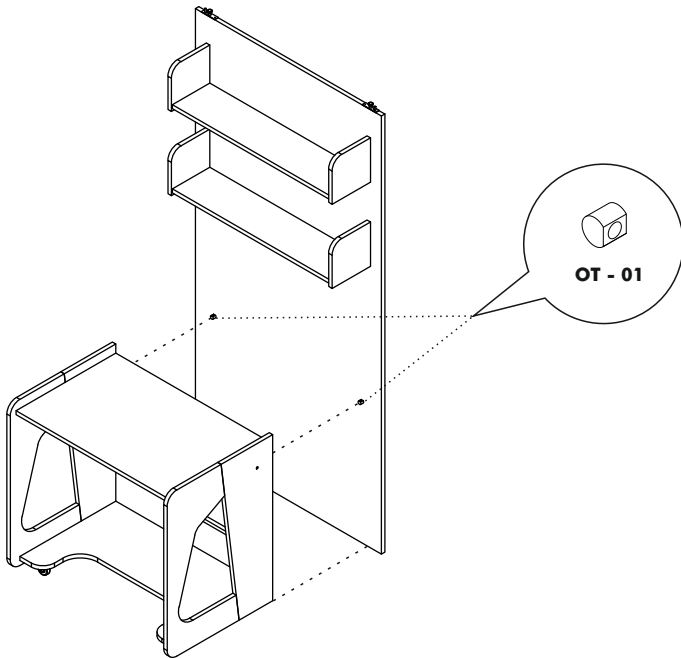

STEP 29



OT-01



YY-01

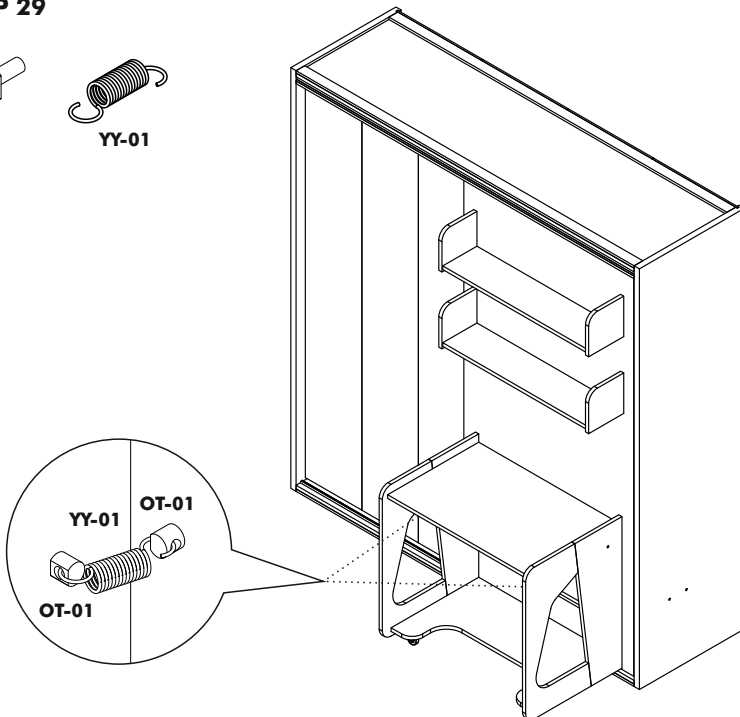

VIDEO

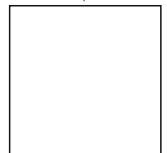

link

STEP 30

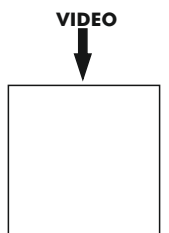
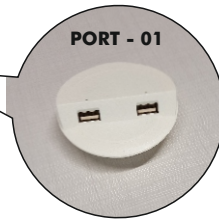
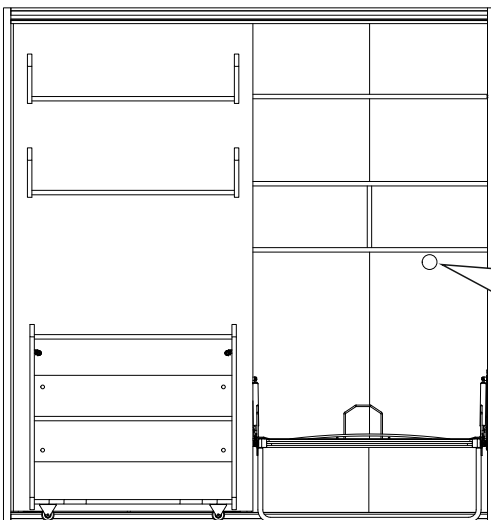
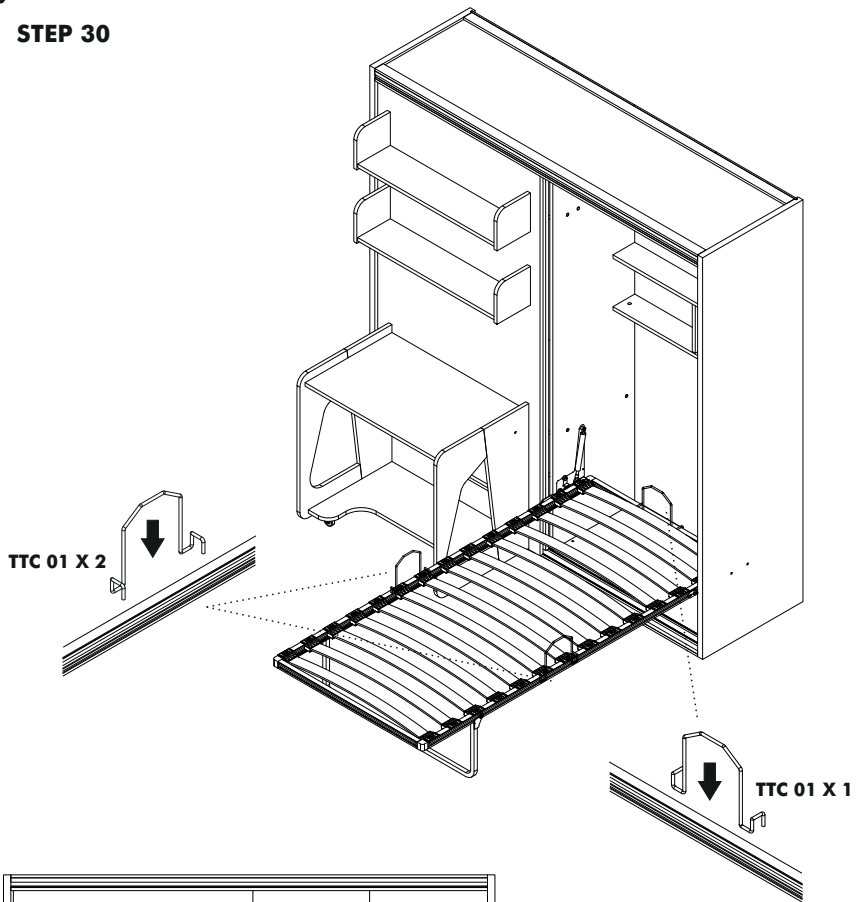

R

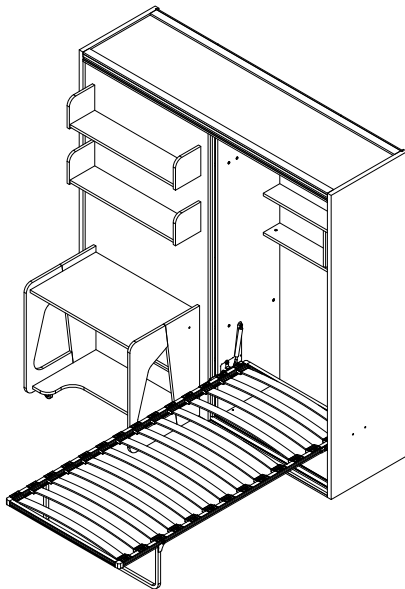
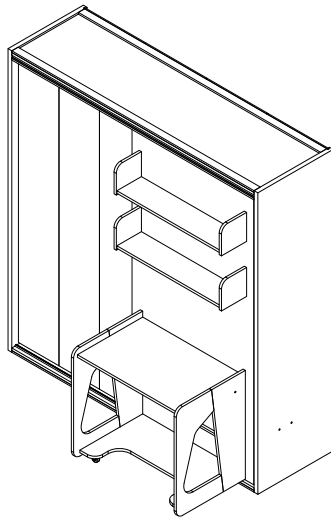

VIDEO

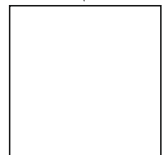

link

L

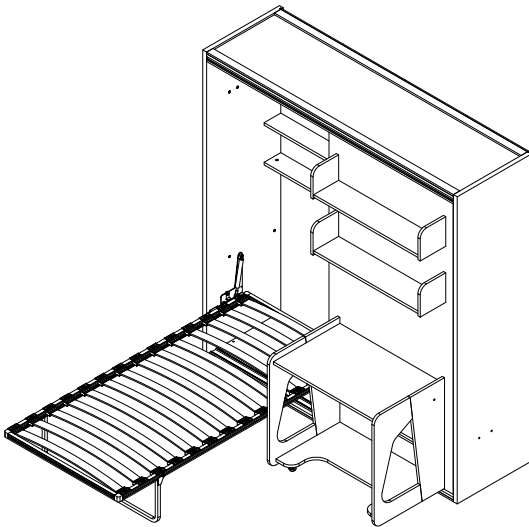
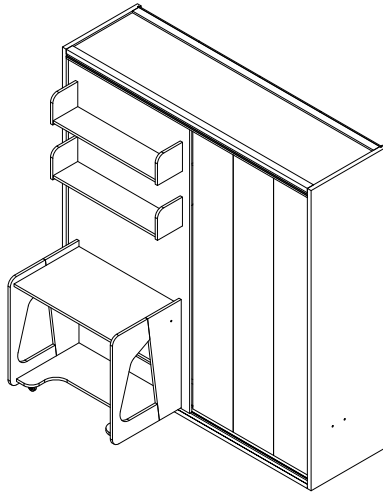

VIDEO

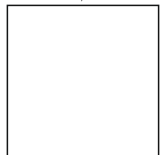

link

ATTENTION / HOW TO / READ ME / OWNER'S GUIDE

1. When mounting on a regular drywall, furniture must be fastened to wood or metal studs. Solid walls made of brick, concrete or similar strong material are also acceptable. Do not mount furniture to paper-mache or sheet rock like material without properly affixing to stud.
2. For safety and product longevity you must periodically inspect the mounting and mechanical connections for integrity and tightness. Confirm hardware remains properly affixed and connections snug.
3. Wall Bed mattress thickness may not exceed 8 inch. Take care to remove pillows and excess blankets before closing. Doing so keeps mechanism free of obstruction and unnecessary stress.
4. Do not lean or rest heavy objects on side or top of furniture. This may cause balance issues and compromise the integrity of your mounting connections.
5. Please use the furniture's beds, desks and shelving as intended. Not designed to be sat, stood, leaned, jumped (etc) on. Improper use may cause personal injury and damage to property.
6. With seasonal humidity change you must inspect interior and exterior of furniture.
7. Single, Twin, Twin XL beds accommodate the weight of one person. Improperly sleeping more than one person risks injury to person and damage to property.
8. Before any un-mounting or disassembly please contact Multimo for technical support and instruction. Failure to properly detach risks injury to person and damage to property.
9. For Bunk Beds:
 - a. Always use provided ladder when accessing top bunk.
 - b. Be slow, careful and aware of surroundings when opening top bunk.
 - c. Do not horseplay. Beds are to be slept on only.
 - d. Some have legs that fully extend when open- be aware of where the leg is and will be.



MULTiMO

www.multimo.com